



Insulating Unvented Attics With Spray Foam

Closed-cell polyurethane foam provides the insulation, air barrier, and vapor retarder necessary for an unvented attic assembly

by James Morshead

As a general contractor, I was taught that attic and cathedral ceiling assemblies should always be vented. Since then, however, studies have shown that properly designed and installed unvented attic assemblies outperform vented assemblies. They reduce energy loss and protect against rot and mold by preventing moisture from passing through the insulation and condensing on cold surfaces. Although many builders — and even some building inspectors — are unfamiliar with them, unvented assemblies are already part of the 2006 IRC and will soon be allowed by most building codes (see sidebar, page 5).

I work for a company in Northern California that installs spray polyurethane foam (SPF) insulation, and we are frequently asked to

Insulating Unvented Attics With Spray Foam



Figure 1. Spray foam is a good choice for roofs that are difficult to vent, like a turret with converging rafters (left) or a flat roof with its rafters hung between flush beams (right).

insulate unvented assemblies. Sometimes the building has a flat roof or a cathedral ceiling that would be difficult or impossible to ventilate (Figure 1). In other cases, the existing framing cavities are too shallow to accommodate a sufficient amount of insulation plus a vent space. And occasionally customers request unvented attics because they make the building more comfortable and energy-efficient.

Why Install Roof Venting?

Traditionally, venting has been used to deal with problems that occur when heat or moisture escapes into the attic (Figure 2, page 3).

In cold climates, the escaping heat can cause ice dams by melting the snow on the roof. Venting the space above the in-

insulation helps keep the roof cool by carrying this heat away. If moisture enters the attic through the ceiling (usually as an air leak), the vents are supposed to allow it to exit before it condenses on something cold.

However, ventilating above fiber insulation comes with an energy penalty. Fiber insulation is designed to be enclosed in an airtight cavity. When air flows over and through fiber insulation, there is a substantial loss of thermal performance.

Also, most hvac ducts and air handlers leak to some degree, so when these are installed in vented attics, conditioned air is lost to the exterior. And because vented attics are subject to extreme high and low temperatures, additional energy

Vented vs. Unvented Attics

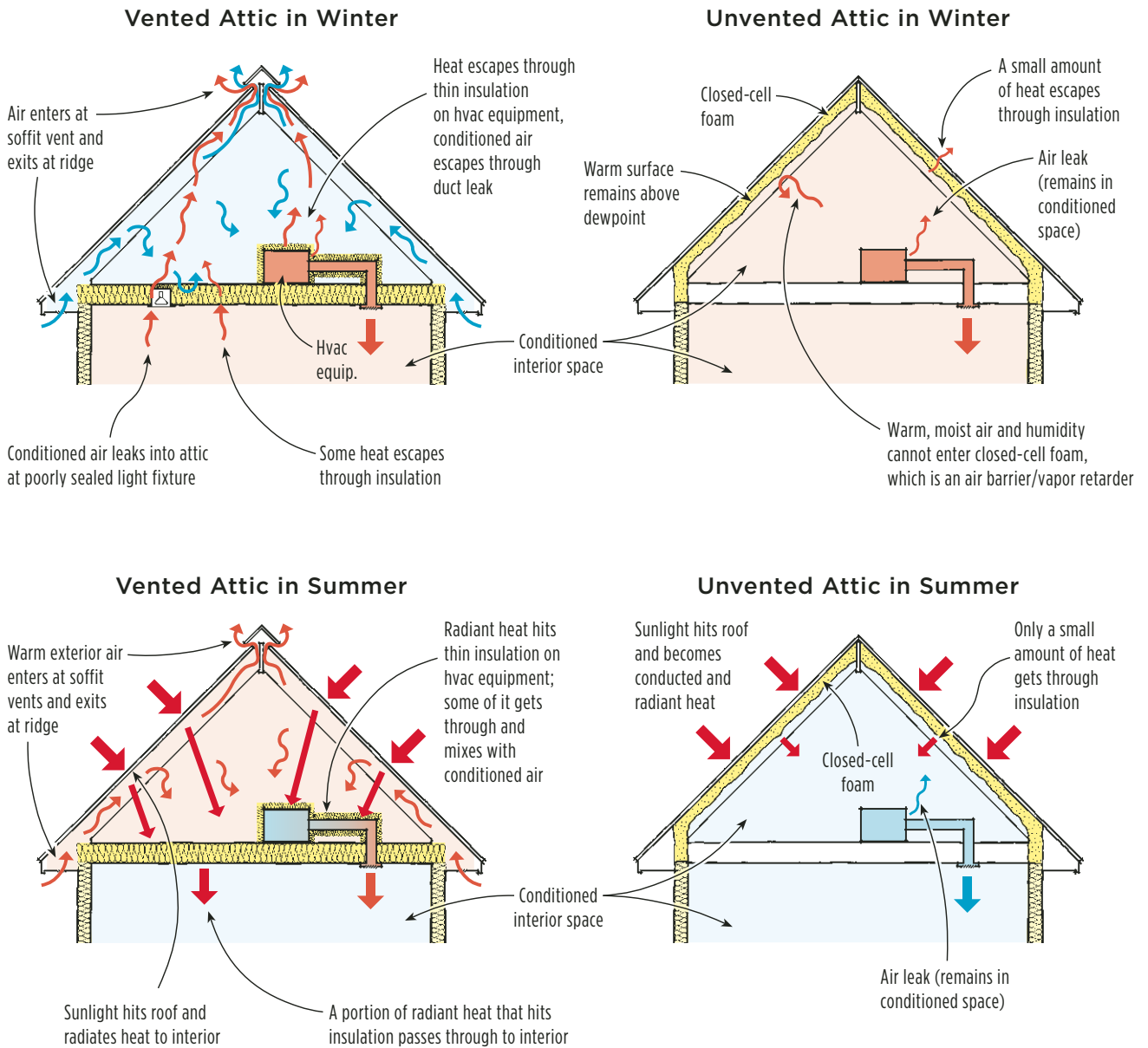

Figure 2. While attic ventilation can mitigate problems caused by ineffective insulation or leaky air or vapor retarders, a better approach is to build the attic as an unvented assembly. The foam insulation used for unvented attics stops air movement and with it the transport of moisture. Any hvac equipment located in the attic is within the conditioned shell of the house, which also cuts energy losses.

is lost through the thin insulation on the hvac equipment.

In cooling climates, venting the attic can bring humid outdoor air into contact with attic ductwork. If the ducts are not properly insulated, they can be cold enough to cause condensation.

Venting and shingle temperature. It's a common misconception that code-required venting significantly lowers the summer temperature of the roof surface. In fact, tests have shown that it lowers the surface temperature of asphalt shingles by at most about 5°F.

For many years, roofing manufacturers required that shingles be installed over vented substrates, but today, several companies — including Elk and Certain-Teed — will guarantee shingles installed over properly constructed unvented roofs.

Insulating Unvented Attics With Spray Foam



Figure 3. The ducts visible in this unvented attic will be concealed after drywall is installed. But because they are in conditioned space, they won't be subject to the extremes of temperature typical of attics.



Figure 4. This barrel ceiling (above) would be difficult to insulate and seal with traditional materials. It's an ideal candidate for spray foam, which conforms to its irregular surfaces (left).

How Unvented Assemblies Work

A properly constructed unvented attic is immune to the moisture problems that occur in vented assemblies and is much more likely to be energy-efficient.

In an unvented assembly, anything below the insulation — including an attic — is considered conditioned space. Turning the attic into conditioned space saves energy; if heat or air escapes from the hvac equipment, it remains within the conditioned space (Figure 3).

If enough energy is saved in this manner, the hvac system can actually be downsized, reducing installation and operating costs.

A number of insulation materials can be used in an unvented assembly, but the one with the greatest applicability across the country is SPF. It's an extremely effective insulation and air barrier all in one, and since it's spray-applied, it conforms to irregular shapes that otherwise might be difficult to insulate and seal (Figure 4).

Despite the multiple brands of SPF, there are only two main kinds: open-cell foam and closed-cell foam. Chemically, all brands are nearly identical — contrary to some advertising claims — and contain about the same proportion of agriculturally derived resin from corn, sugar beets, sugarcane, or soybeans. None of the spray foams contain formaldehyde or use toxic or ozone-depleting blowing agents.

The important differences between products have to do with density, R-value, and permeability.

Open-cell foam. The typical open-cell foam weighs 0.5 pound per cubic foot and has an insulation value of R-3.5 per inch of thickness. This type of foam is relatively permeable; at 5 inches thick it is rated at about 10 perms. Open-cell foam

is an air barrier but not a vapor retarder.

When sprayed, open-cell foam expands to about 100 times its liquid volume, so it usually has to be trimmed flush to the framing. Fortunately, it's soft and easy to trim.

Closed-cell foam is denser and less permeable than open-cell material. The typical closed-cell foam weighs 2.0 pounds per cubic foot and provides R-6.6 per inch of thickness.

When sprayed, closed-cell foam expands from 30 to 50 times its liquid volume, making it easy to apply without completely filling the framing bay. If the bay must be filled completely, the applicator can overfill it and then trim off the excess.

Trimming closed-cell foam is not as easy as trimming the open-cell material, but it can be done.

Advantages of Closed-Cell Foam

Both types of SPF are excellent insulation materials, but our company uses closed-cell material in unvented assemblies because we think it provides the best overall performance. With it, we can pack more R-value into a small space, which is helpful when the existing rafter bays are shallow; for example, we can get R-30 into a 4¹/₂-inch space.

In our climate zone, it's important to avoid excessive vapor diffusion, and we think the best way to do this is to use closed-cell foam. One of the great benefits of closed-cell foam is that if you install it to a thickness of at least 2 to 2¹/₂ inches, it will have a permeance of 1.0 perm or less.

This means that in addition to being an air barrier, closed-cell foam is a vapor retarder. It's actually a vapor retarder from both sides, so it ends the debate about which side of the insulation to put the vapor retarder on in climates where

Code Provisions for Unvented Attics

Every state except California and Hawaii has adopted some version of the IRC. And California is expected to adopt it in 2008.

Until recently, the IRC required all attics and enclosed rafter spaces to be vented. But the latest version allows unvented attic assemblies if certain conditions are met.

According to Section R806.4 of the 2006 IRC, unvented assemblies are allowed if "no interior vapor retarders are installed on the ceiling side (attic floor) of the unvented attic assembly" and if "air-impermeable insulation is applied in direct contact with the underside/interior of the structural roof deck."

There is an exception that allows air-permeable insulation (fiberglass and cellulose) to be used in unvented assemblies in certain parts of the South (climate zones 2B and 3B).

It has long been possible to get an unvented assembly approved by the inspector as an "alternate construction method." But once states update their codes to the 2006 IRC, it will no longer be necessary to get special approval for unvented assemblies.

In the meantime, the fact that the 2006 IRC allows unvented assemblies should make it easier to get special approval in states that have adopted earlier versions of the code.

Do not build an unvented attic assembly without first talking to the local building inspector. Unvented assemblies are new in the IRC, and your state might be using an older version of the code. Also, the committee that wrote this section is still working on it, so more changes may be on the way.

interiors are both heated and cooled.

Some companies that make both open-cell and closed-cell foam advise insulation contractors not to use the open-cell material in unvented assemblies — or to do it only in certain climates where vapor diffusion will not be a problem.

In conditions of extreme vapor drive — an indoor pool or spa, for instance — it may be necessary to further reduce the permeability of closed-cell foam by coating it with a spray-applied liquid vapor barrier.

Cathedral Ceilings

In a vented cathedral ceiling, the insulation is in contact with the back of the drywall and there's an air gap (the venting space) above. But in an unvented assembly, the insulation must be against the bottom of the sheathing.

Sometimes, if the rafter bays are unusually shallow, we have to fill them all the way up with closed-cell foam (Figure 5, page 6). But because this type of foam has such a high R-value, in most cases we have to fill the cavities only partway.

Contractors often ask about the air

Insulating Unvented Attics With Spray Foam



Figure 5. Open-cell foam, which expands to about 100 times its liquid volume, typically has to be trimmed flush to framing members — an easy task, since the foam is so soft. Because of its lower expansion rate and higher R-value per inch, closed-cell foam doesn't usually have to be trimmed. When it does, as in this shallow rafter bay (left), the author's crew uses a scraper — in this case a horse curry comb — to clean the framing in preparation for drywall (right).



Figure 6. Fiberglass and cellulose insulation are usually installed in contact with the back of the drywall; the concern is that leaving a space there allows convective air currents to degrade the insulation's thermal performance. Because closed-cell foam is unaffected by air movement, the space between it and the drywall is not a problem.

space below the foam; most were taught that it's bad to leave an air space below insulation. This is true of fiber insulations because convection currents can form in gaps and degrade the insulation's thermal performance. But it is not true of foam, which can't be infiltrated and is relatively unaffected by surrounding air currents.

Any space left below the foam is considered conditioned space (Figure 6).

Dealing With Can Lights

It's easier and more energy-efficient to build a cathedral ceiling as an unvented assembly, but dealing with recessed light fixtures can be a real challenge.

There are two issues: how to insulate and seal the area above the fixture, and how to provide enough space around it so it doesn't overheat. Even if the fixture is an IC unit, you can't embed it in foam.

Insulating above. If we're lucky, there



Figure 7. Code requires that a space be left between can lights — even IC-rated cans — and spray foam insulation. In shallow bays, the author’s crew installs foil-faced rigid foam above fixtures and creates a seal by lapping the spray foam onto it (left). An alternate method, which may soon be required in California, is to isolate fixtures from the foam by installing them in metal boxes (right).

will be room to spray a full thickness of foam above the fixture and still maintain the desired 2 to 3 inches of clearance between foam and fixture.

If there isn’t enough space or access to spray above a fixture, we sometimes install a piece of nonperforated foil-faced rigid foam above it instead. Before spraying, we mask the fixture to keep it clean, then create an airtight seal by lapping the SPF onto the rigid foam (Figure 7). If the rigid foam butts to framing, we caulk that joint with polyurethane sealant.

Clearances. Few building codes contain specific requirements about clearances between foam and can lights, so it’s a good idea to talk to the building inspector about the issue. SPF is such a good insulator it can cause a fixture to overheat, tripping the temperature-limit switch and cutting power to the light. Excess heat could also damage the wire sheathing or even the foam itself.

In California, new code provisions are being developed that will require builders to take one of three measures with recessed lights: leave 3 inches of clearance around a fixture, box around it, or wrap it with 2 inches of mineral fiber. A 3-inch clearance is already required around hot appliance vents.

SPF is compatible with PVC and CPVC, so it’s okay to spray it on Romex, PVC pipe, and CPVC sprinkler pipe.

Air Sealing

Any surface we spray will be sealed against the movement of air, but there are always some surfaces we can’t spray.

For example, the gaps between doubled-up framing members are too small to spray with foam, yet a significant amount of air can leak through at these spots. It’s best to seal these joints during framing by installing compressible foam gaskets between the members. If that

isn’t done, you can caulk the joints after the foam is installed.

When the gaps are too wide for caulk, we fill them with foam from a can. The canned foam should be the low-expansion type; it contains more closed cells than the high-expansion material. We stay away from the latex foams because they’re very permeable.

Fire Resistance

When the unvented assembly is a cathedral ceiling, the foam will be covered with drywall, which is a code-approved thermal barrier. In an attic, though, the rafter bays are not normally covered by drywall, so the issue of fire-resistance comes into play (Figure 8, page 8).

This can be a gray area in the code, so be sure to check with your building department before building an unvented attic space. Most codes state that if the attic is accessible for the service of

Unvented Roof Details

Cathedral Roof Detail

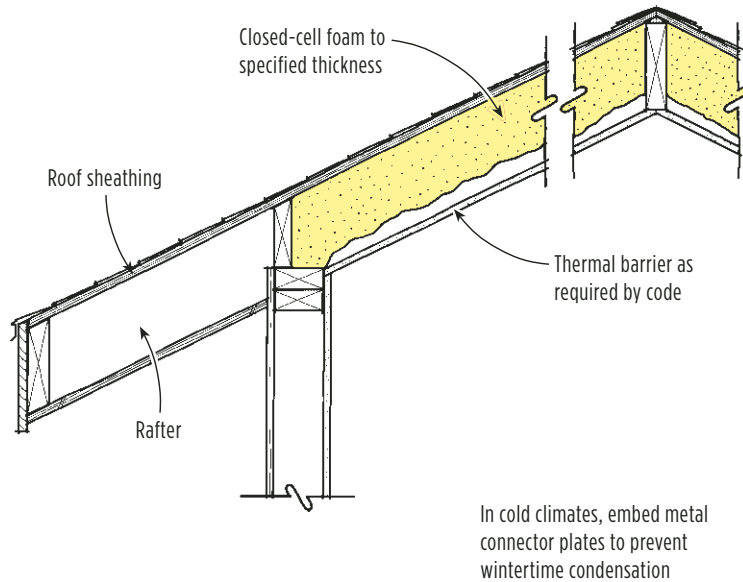

Conditioned Attic Detail

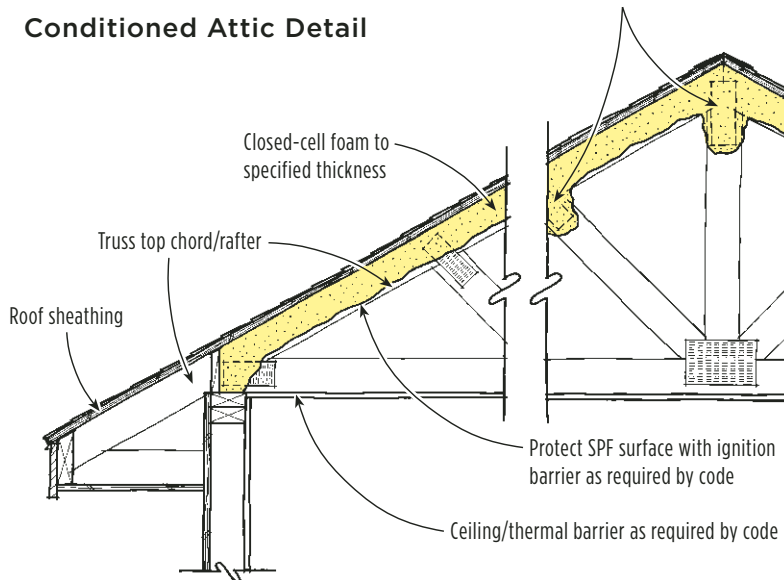

Figure 8. When insulating an unvented roof assembly, the author prefers closed-cell to open-cell foam because it's both an air barrier and a vapor retarder. To finish an unvented cathedral ceiling insulated with closed-cell foam, most codes require a layer of 1/2-inch drywall or an equivalent thermal barrier (top). Depending on local code, the spray foam in an unvented, or "cathedralized," attic (above) may not require drywall covering unless the area is accessible for servicing equipment. In some cases, the foam may have to be sprayed with an intumescent coating.

utilities, the foam must be covered with an ignition barrier. Certain water-based intumescent coatings qualify as ignition barriers.

If the attic area is not accessible or is not "accessed for the service of utilities," it may be possible to leave the SPF exposed. Many contractors are confused about how to treat this enclosed attic space. Providing access through a ceiling hatch is okay but not necessary; venting to the room below is prohibited by the fire code.

Other Issues

Unlike fiber insulation, which can be blown through a hose or stuffed into hard-to-reach areas, SPF can't be installed without sufficient access. The applicator must be able to get close enough to the sheathing to spray from 16 to 24 inches away — and do it from pretty much straight on.

Cost. In our area, the installed cost of an average-size closed-cell foam insulation project is between \$1.10 and \$1.40 per board foot of material.

For R-30, that comes to about \$5 per square foot of roof area. That's more than other insulation materials would cost, but not much more if you factor in all of SPF's advantages — future energy savings, increased comfort and moisture control, the greater design flexibility that comes with being able to fit the necessary R-value into small framing cavities, and the possibility that the mechanical system can be downsized.

James Morshead is senior project manager and technical director for American Services Co. in Dublin, Calif.